

AUTOMATIC MULTI-PISTON SYSTEM

SIX OR EIGHT PISTON BATTER DEPOSITOR WITH CONVEYOR AND PAPER CUP DENESTER

Turn-Key Muffin & Cake Production System

Knowing the importance of valuable facility floor space and tight budgets, Hinds-Bock has engineered the perfect batter production system for mid-size bakery production facilities. The system comes complete with a built-in conveyor and a Veropak® paper cup Denester.

This all in one "COMBO" system matches well with mid-size wholesale bakeries and central commissaries looking to easily and quickly increase production, control ingredient waste, and improve consistency and accuracy in one efficient package. The combination of the robust and industrial level batter depositor with the industry leading paper cup denester creates the most versatile tool on your bakery floor.

Muffins, cupcakes, snack cakes, round cakes, loaf and straps all run through this system with ease. Stand alone operation or in-line with upstream pan oilers and down stream topping equipment the production of the system can support very high production levels.

Typical 6 x 4 pans run wide-edge-leading can be lined and deposited at rates of **800 - 1200 DOZEN PER HOUR!**



Integrated Veropak® automatic paper cup dispenser



FEATURES:

- SIX (6) piston machine for ultimate flexibility.
- CHANGE PARTS available for small deposits.
- Allen Bradley PLC with recipe memory for various pan configurations.
- Stand-alone system or installed in-line on your existing baking line.
- Integrated Veropak® paper cup dispenser.
- Portable frame for moving within bakery.
- Competitively priced with quick ROI.
- Pass through design for loaves, rings, and strapped pans.
- Lead edge adjustment of depositor head for tuning presentation.
- Dual DELRIN flat-top chain pan drive with EAZY clean lift up design.
- Multiple illuminated E-Stop locations and fully guarded for operator safety.

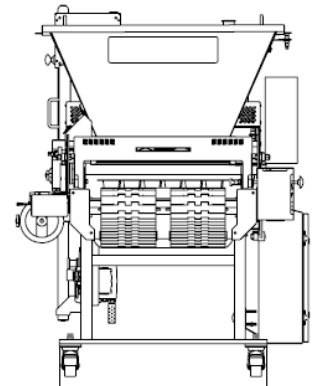
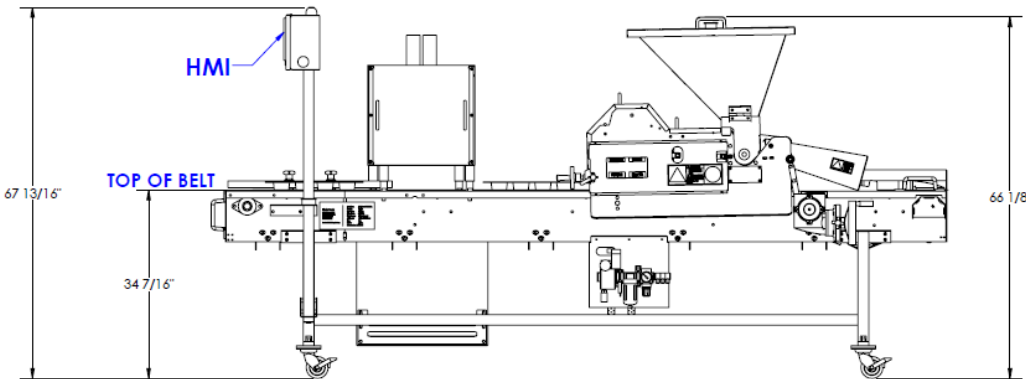
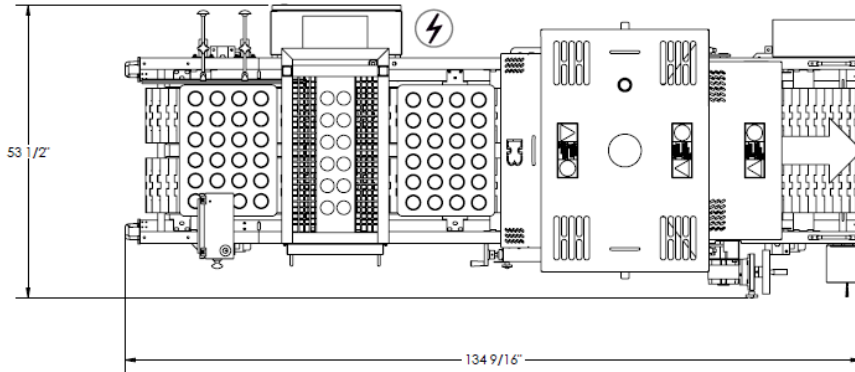

RATES AND MEASURES:

1.5oz - 8oz CAPACITY PER PISTON
 UP TO 45 CYCLES PER MINUTE (8 - 10 PANS PER/MIN TYPICAL)
 LARGE INCLUSIONS, BERRIES, NUTS, ETC.
 CAKE BATTERS THICK AND THIN

UTILITIES INFORMATION:

POWER =
120 VAC | 1 PH | 15 AMP
 AIR =
15 SCFM - DEPOSITOR
30 SCFM - CUP PLACER



2122 - 222nd ST SE
 Bothell, WA 98021
 1.425.885.1183
 1.877.292.5715
 sales.inquiries@hinds-bock.com

