

# PISTON FILLERS/DEPOSITORS

## 2P-64 Twin Piston Model

The Hinds-Bock twin-piston filler/depositor is the classic workhorse of the food processing industry. Easy to clean and operate, versatile and gentle on all products, it provides immediate cost-saving results. Large port openings permit filling of large particulates without crushing. USDA and AG Canada approved.

### PARTIAL PRODUCT LIST:

- Jams & Jellies
- Pie Fillings
- Cake Batters
- Flowable Dough's
- Fruit Cake Batters
- Fruit Puree
- Mayonnaise
- Salad Dressings
- Potato Salad
- Macaroni Salad
- Cole Slaw
- Burrito Fillings
- Meat Pie Fillings
- Stews
- Soups & Sauces
- Relish
- Mustard
- Ketchup
- Caramel
- Cream Topping
- Salsa
- Chili
- Baked Beans
- Dips & Spreads
- Shampoo
- Creams & Lotions
- HOT OR COLD PRODUCTS



### STANDARD FEATURES

- Air powered – consult factory for compressed air requirements
- 14 inches of height adjustment
- Locking swivel casters
- Stainless steel construction with all contact parts of food-approved materials
- Fills from fractions of an ounce to 64 ounces per piston with change cylinders
- Standard air cylinder drive or independent drive

E-mail: [info@hinds-bock.com](mailto:info@hinds-bock.com) | Web: [www.hinds-bock.com](http://www.hinds-bock.com)

# Options Available to Match Process Requirements

Options Include: Rectangular (25-40 gallon) hoppers, "U"-shaped agitated hopper, wiping blade depressor agitators, change cylinders, a variety of spouting, automatic & semi-automatic controls, level probes... all matched to customers' applications

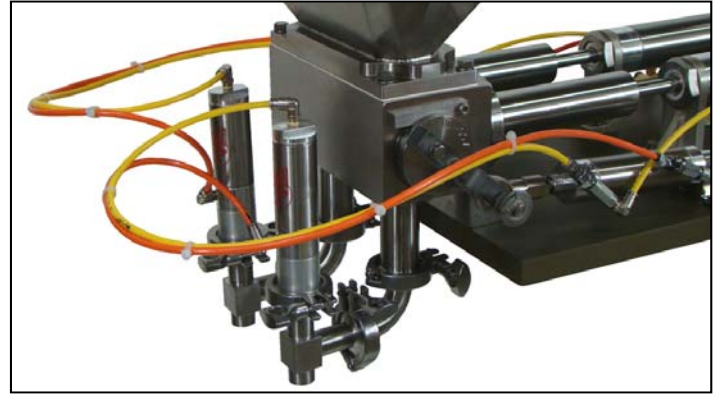

2P-64IND and P-128 Product Transfer Pump  
The Classic Workhorse Duo!

Hinds-Bock has specialized in the design of fillers/depositors since their beginning in 1976. These labor-saving fillers/depositors all provide:

- ❑ Improved quality when depositing large, delicate particulates, damage free.
- ❑ Reduced costs with accurate filling/depositing into trays, bottles, cans, pouches, or targeted into baking pans as pictured below.
- ❑ Improved payback with versatility, ease of maintenance and operation.

1" Vertical Cut-Off Spouts filling mustard

ASK ABOUT CUP & TRAY DENESTERS AND LID APPLICATORS  
ASK ABOUT TRANSFER PUMPS TO FILL THE HOPPER

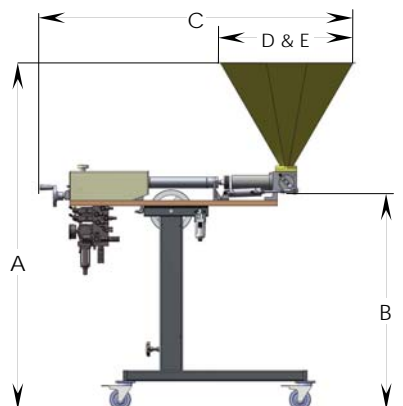

Standard Model Specifications				HOPPER WIDTH		*
MODEL	A	B	C	D	E	REQ'D CFM
2P-64 DUAL PISTON	66"–80"	41"–54.5"	59"	25.75"	32.25"	6-8

\*Approximate CFM. Consult factory for exact CFM requirements.